

TUXCO

Model HCS - 60

Hydraulic Cylinder Servicer

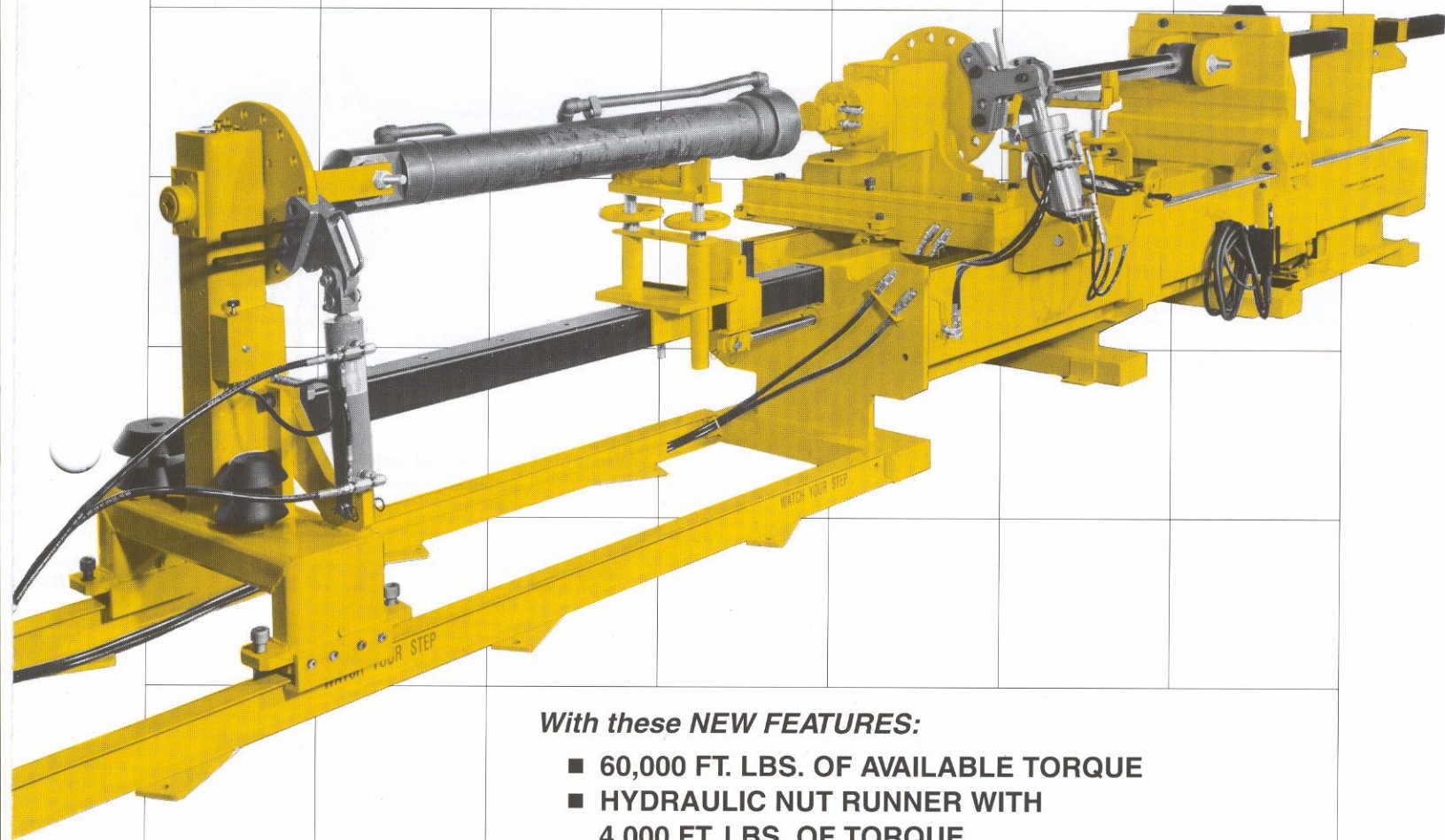

With these NEW FEATURES:

- 60,000 FT. LBS. OF AVAILABLE TORQUE
- HYDRAULIC NUT RUNNER WITH 4,000 FT. LBS. OF TORQUE
- EIGHT HYDRAULICALLY POWERED FUNCTIONS
- CONVENIENT PENDANT CONTROL

*plus all the features that have made
TUXCO the industry leader.*

TUXCO CORPORATION

4300 Grove Avenue, Gurnee, Illinois 60031-2155 USA

Tel.: 847-244-2220
FAX: 847-244-7335

EYE LEVEL TORQUE GAUGE

reads applied and break-away torques for threaded rod retaining caps

POWERFUL HYDRAULIC NUT RUNNER

provides 4,000 ft. lbs. of torque at 6 r.p.m. to quickly unscrew and screw on piston retaining nuts. It is pendant controlled.

DOUBLE ACTING TORQUER

has adjustable torque output and is pendant controlled.

QUICK SET UPS

new cone-shaped adapters are conveniently stored at the headstock and tailstock where they are used.

HYDRAULIC INDEXING FEATURE

has 4 ft. (1219mm) repeatable stroke and tons of power to extract and insert piston rods in seconds.

WATCH YOUR STEP

WATCH YOUR STEP

EIGH

If you frequently repair big, hard to handle and highly torqued cylinders, Tuxco's HCS-60 was designed for you. And while it's built to do the big and tough ones, it is versatile and easy to use on the full spectrum of hydraulic cylinders that a busy shop encounters. No other service bench provides as many hydraulically assisted functions.

SET UPS ARE QUICK AND EASY

The tailstock chuck hydraulically moves back and forth the length of the machine bed, quickly adjusting for cylinders of varying lengths.

Mounting the rod and barrel ends securely is quick and easy. Only three sets of four cone-shaped mounting adapters handle all eye bushing I.D.s from 1.500" to 8.00".

CYLINDER BARRELS STAY IN THE MACHINE

If the cylinder has a threaded head, using the universal spanner and the 30,000 ft. lbs. of torque provided by the headstock hydraulic torquer, it can quickly be removed. But threaded or bolt-on, once the head is removed a powerful long stroke indexing cylinder quickly moves the barrel out of the way.

WORKSTATION PARKS HYDRAULICALLY
pendant activated hydraulic system quickly moves the workstation out of the way, brings it back to its working position effortlessly and in seconds.

PUSH BUTTON CONTROLLED HYDRAULIC SYSTEM
moves tailstock chuck quickly to set up the machine for cylinders of varying lengths.

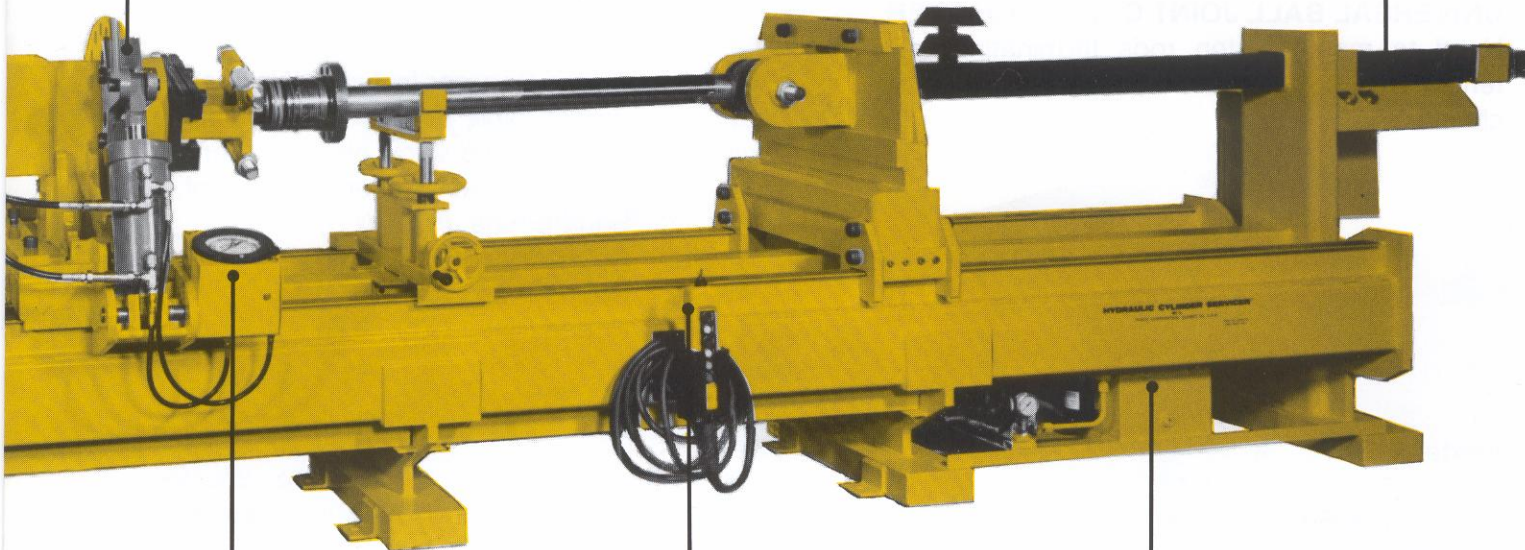

60,000 FT. LBS. OF AVAILABLE TORQUE AT THE WORKSTATION
to handle the toughest piston retaining nuts. Torquer is adjustable, double acting and pendant controlled. Gauge reads and records applied torque.

HEAVY DUTY PENDANT CONTROL
has 25 ft. cable, puts seven of the machine's eight hydraulic functions at the operator's finger tips.

7.5 H.P. HYDRAULIC POWER SUPPLY
has 3 phase, multi-voltage motor, 5 gallon tank, filter and sight gauge. Flow is controlled by 24 v. DC solenoids.

T HYDRAULIC FUNCTIONS INCREASE PRODUCTIVITY

HYDRAULIC WORKSTATION MAKES SHORT WORK OF PISTON RETAINING NUTS

At the push of a button the workstation moves from its parked position to the centerline of the machine. With the proper high torque tool snapped into place, hydraulic power is used to engage the nut. At the push of a button a 60,000 ft. lbs. hydraulic torquer breaks loose the nut and a 4,000 ft. lbs., 6 r.p.m. geared hydraulic nut runner spins it off. Reversing the process makes reassembly quick and easy.

AND THERE'S EVEN MORE . . .

The HCS-60 includes a universal spanner. You won't need conventional spanner wrenches. It also includes a universal high torque wrench. You won't use expensive conventional sockets. The unit is completely wired. You need only connect it to your electric service. Specify voltage to be used. We even include the floor anchors, anchoring tool and Allen wrenches that are required. You'll be up and running quickly.

Specifications subject to change without notice.

HCS - 60 HYDRAULIC CYLINDER SERVICER ACCESSORIES

Model No. 906 - 60

UNIVERSAL BALL JOINT CHUCK ADAPTER

Used to mount piston rods terminating in a female ball joint to the servicer tailstock T-slot chuck.



Model No. 908 - 60

BLANK CHUCK ADAPTER

Similar to 906-60 but with a blank face that can be machined to accept flanged lift truck cylinders, etc.

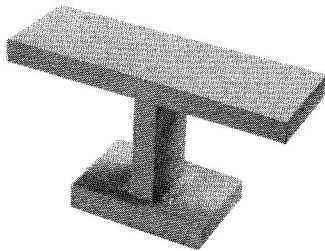

Model No. 909

V-BLOCK CHUCK WINGS

For mounting cylinders in Servicer chucks when the cylinder or rod does not have a pin bushing. For Headstock order No. 909. For Tailstock order No. 909 - 60.

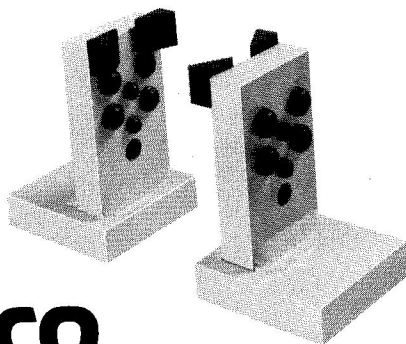

TUXCO CORPORATION

4300 Grove Avenue
Gurnee, Illinois 60031-2155
Telephone 847-244-2220
Fax 847-244-7335

Model No. 919

REPLACEMENT SPANNER PIN ASSORTMENT

Each HCS Series Servicer includes this assortment of spanner pins used with the built-in Universal Spanner. The alloy pins are perishable. The replacement assortment consists of:

- 4 - 1/2" Square Pins (919 1/2 S)
- 4 - 1/2" Round Pins (919 1/2 R)
- 4 - 3/8" Round Pins (919 3/8 R)
- 4 - 1/4" Round Pins (919 1/4 R)

Model No. 965

UNIVERSAL WRENCH

Extra large Universal High Torque Wrench attaches to hex piston retaining nuts requiring 25,000 ft. lbs. of torque or less. Fits nuts from 4" to 6 1/2" across flats.

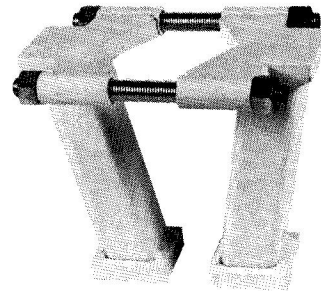

Model No. 975

WORK STATION CHUCK ADAPTERS

These high torque adapters are the only tooling capable of withstanding torques in the 25,000 to 60,000 ft. lbs. range. They are available in 5, 5 1/2, 6, 6 1/2 and 7" hex sizes. Also in 130, 135, 150 and 170 mm hex sizes. Square sizes are available in 135 and 145 mm sizes. Specify size and shape when ordering.

